

THE SUPER PORTABLE CONVEYOR

DESCRIPTION

The C&D Super Portable provides labor-saving efficiency, high productivity, 30 to 40 tons per hour throughput, and the highest landfill diversion rate—up to 75%. With the various options available, the Super Portable becomes a versatile modular sorting system that can be customized to meet your specific needs. The basic unit consists of a two-belt, variable-speed, in-feed system which helps meter the material onto the variable-speed sortline with a 11' clearance underneath.

STANDARD FEATURES

- :: Head shafts: 1045 alloy steel with spherical roller bearings.
- :: Tail shafts: 1020 alloy steel with spherical roller bearings.
- :: Head pulleys: 14" diameter crowned and lagged.
- :: Tail pulleys: self cleaning wing pulleys.
- :: Drives: planetary gearboxes with final v-belt drive.
- :: Belt: 2 ply 600 wear-lock belt.
- :: Chain: double beaded with 5" wheels and 3/8" pans.
- :: Structure: heavy duty structural members, 3/16-3/8" plate.
- :: Bearings: All bearings are spherical Roller type.
- :: Skirting: Special side skirting for handling gritty material.
- :: UHMW lined mains slider pans.
- :: Picking stations: 8-18 stations, catwalks with fold up sides, diamond plate decking, and stairs.
- :: Chutes: 6-9 3'x7' chutes to direct material into drop boxes located beneath the sort line.
- :: Safety Stops: Continuous cable actuation.
- :: Lacing: Stainless steel.
- :: Paint: Custom colors using Columbia Speed Set brand.

OPTIONS

- :: Power: Diesel, electric, 480 V.
- :: Widths: 48", 60" or 72" belt widths.
- :: In-feed Shaft Heights: 16'- 18'6.
- :: Sortline lengths: 62', 84' 114'.
- :: ADC screen: 1.5 minus fines screen.
- :: Fines take away conveyor: troughing roller conveyor.
- :: Magnetics: overhead magnet or magnetic head pulley.
- :: Take away/stack out conveyors: trough roller or slider.
- :: Hopper: Above ground pit with ramp or complete hopper.
- :: Controls: Variable speed control package with LCD touch screen controls.

BENEFITS

- :: Reduced man-hours.
- :: Increased safety.
- :: Huge reduction in landfill fees.
- :: Increase in marketable products.
- :: Lower operating and maintenance costs.



Krause Manufacturing, Inc.

A Division of the CP Group of Companies

6059 Guide Meridian Road

Bellingham, Washington 98226, USA

(t) 360.398.7533 (f) 360.398.2914

(e) info@krausemanufacturing.com

(Or visit us online) krausemanufacturing.com

MANUFACTURED IN
A M E R I C A





THE SUPER PORTABLE CONVEYOR

PORTABLE C&D RECYCLING SYSTEMS.
BUILT TO PERFORM. BUILT TO LAST.
BUILT TO INCREASE YOUR PROFIT POTENTIAL.



CUT LABOR COSTS. INCREASE SAFETY. REDUCE WORKER BURNOUT. INCREASE PRODUCTION. MAXIMIZE LANDFILL DIVERSION.

Today's C&D recyclers need high-quality, heavy-duty automated sorting equipment that gets the job done consistently, reliably and at the greatest return on investment. For small operations with big requirements, the challenge is finding the equipment that fits your specific needs and budget. The solution: Krause Manufacturing's Super Portable Conveyor System.

The largest and best-built portable C&D sorting conveyor available, the Krause Super Portable sets up easily on virtually any surface, requires no pre-installation investment, and is capable of handling even the biggest and heaviest C&D separation application. With processing capacities of 30 to 40 tons per hour, the rugged Super Portable is also super-dependable, providing recyclers with years of heavy-duty cost savings and low-maintenance operation.

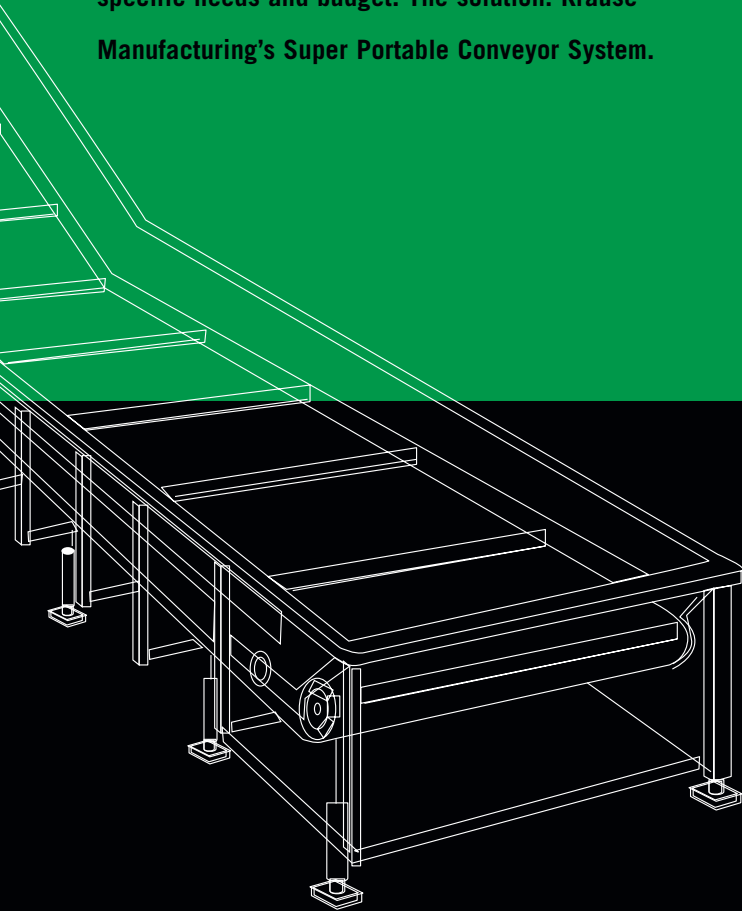

THE MAXIMUM RETURN ON YOUR INVESTMENT—AUTOMATICALLY.

Your separating capabilities will be greatly enhanced when you put the Super Portable to work for your business. Combining automated sorting with improved ergonomics, this system reduces employee physical bending and lifting, which not only speeds up production, but can significantly reduce onsite injuries and worker burnout. With the Krause Super Portable, your company will begin to immediately benefit from reduced man-hours, higher throughput, lower costs, an increase in marketable end products, and a huge reduction in landfill fees.



FLEXIBLE, FAST AND EASY—ANYWHERE.

Because the Super Portable is manufactured in large sections and set up on a series of skids and axle frames, it can be installed quickly and easily on any level surface—gravel, pavement, concrete or dirt. You don't need a permanent facility or a bolted-in stationary system; all that's required is the power feed, which could be provided by a gen-set on remote locations.

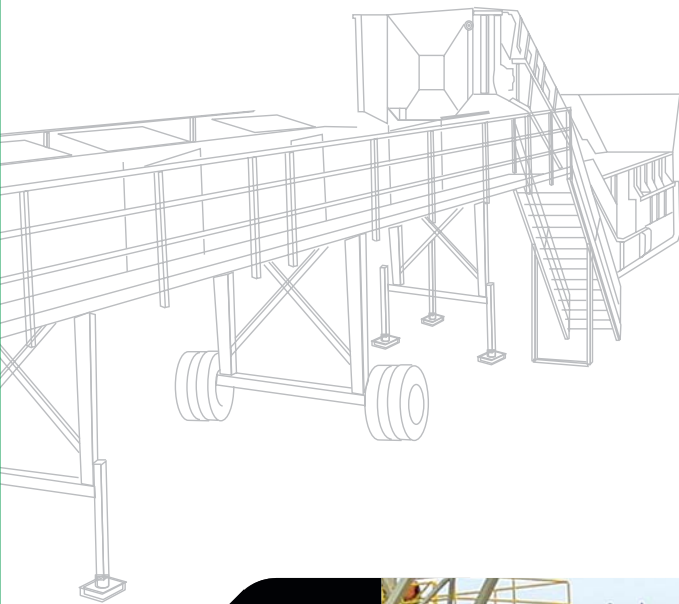

DESIGNED, INSTALLED AND BACKED BY KRAUSE MANUFACTURING—THE QUALITY AND VALUE LEADER.

Krause is the leading manufacturer of heavy-duty automated C&D sorting systems, with a twenty-year reputation built on top quality heavy-duty construction, unequalled durability and superior customer service. We will build your Super Portable in our own plant in the U.S.A. to ensure quality control and the best customized solution for your needs. With Krause Manufacturing, you can be sure that you are getting the best C&D recycling system for your money—one that will provide the highest value and the highest return on investment over the lifetime of your equipment.

